

Absolute Zero Lab *How low can you go?*

Name: _____ Partner: _____

The temperature of a gas sample is a measurement of how fast the particles in that sample are moving. (More precisely, it's a measurement of the average kinetic energy of the particles). As we heat up a gas sample, its particles move faster and faster (the kinetic energy increases), and as we cool it down, the particles move slower and slower (the kinetic energy decreases). If this is so, it only stands to reason that there must be a *lower limit* to the temperature scale-- a temperature where the particles have stopped moving all together! And one could never get anything colder than that temperature, for if the particles have stopped moving, they obviously can't move any slower. This minimum temperature does in fact exist, and it is called **absolute zero**. Certainly the Celsius scale is not an absolute scale, for one can easily reach temperatures below zero degrees Celsius. 0°C is just the temperature where water freezes, and even when water freezes, its particles are still vibrating at hundreds of miles per hour! You would have to cool something down a lot further to get its particles to stop moving all together. Most people have heard of liquid nitrogen and consider it to be very cold, and it is: -196°C. Nonetheless, even at this low temperature, particles still have quite a bit of kinetic energy left. So how low do you have to go to reach absolute zero? Even though we can't get that low, we can figure it out in a rather simple way:

First, realize that a gas sample is mostly empty space. The particles themselves are so small, we can pretty much ignore their size. It is the space between the particles that accounts for 99.9% of a gas's volume. And what keeps this space between the particles is the fact that the particles are constantly moving around and bouncing off one another. As the sample cools down, and the particles slow down, it should be easy to see that they would not create as much space between them, and so the volume would decrease. It follows then that if we can cool a gas down far enough so that the particles stop moving, we could get rid of all of the space between the particles and the volume would become essentially zero. *We can't get that cold*, but we can measure the volume of some gas samples at high temperatures and then measure their volumes again at lower temperature. We can plot these data and extrapolate backwards to determine approximately how cold we would have to get the sample to make their volumes zero. Extrapolate means to "go beyond the data points" to predict the graph.

Procedure:

1. There are two closed-end syringes at each lab station: one with a small trapped air space, and one with a larger one. Pick the smaller one first and submerge the entire body of it in the ice water bath for ~30 seconds. Compress the gas slightly by pushing the plunger down, then release it and watch the plunger spring back. When it has stopped moving, observe and record the volume of the trapped air in the appropriate square in the table below. Record the temperature of the water as well. This will be the volume & temperature of the gas in ice water.
2. Now hold the syringe in the boiling water, wait ~30 seconds, and observe. When the plunger has stopped moving, record the new volume. Use 85°C at the temperature of the boiling water (because the air in the syringe only gets 85°C) *(the rocks in the beaker provide a surface for the bubbles to form on, to control the rate boiling)
3. Repeat steps 1 & 2 for the large gas samples.

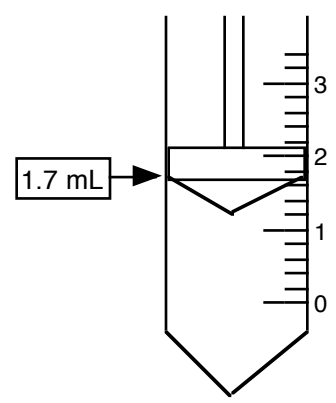

enter this data on classroom computer:

Data Tables

small sample	temp (°C)	volume (mL)
in cold water		
in hot water	85.0°C	

large sample	temp (°C)	volume (mL)
in cold water		
in hot water	85.0°C	



Treatment of the data:

Plot your temperature and volume measurements on the graph. Plot all the data on the same graph, but use **different symbols** for the small & large sample. (Maybe use an 'X' for the small one, and a circle ^o for the large) Look at the data points for one gas sample; they should show a high volume at the high temperature, and a smaller volume at the lower temperature. Connect these points with a *very straight* line (use a straight edge). Next, **extrapolate** (extend) this line backwards to determine how cold you would have to get the sample to cause its volume to be zero. Repeat this technique with the other gas sample.

Questions

1. Your value for "absolute 0" will be the point where your line crosses the X-intercept (volume = 0). Based on your graphs and extrapolations, what value did you get for absolute zero, for the...

...small sample? _____ ... for the large sample? _____

...the CLASS AVERAGE: _____ ... % error: _____

2. As the temperature of a gas sample decreases, its volume _____.

(This is known as Charles's Law)

3. Why does this happen?

4. What is temperature?

5. Why must there be a bottom to the temperature scale?

6. What happens to the particles at this bottom temperature?

7. Why were you told to submerge the entire body of the syringe in the hot & cold water?

8. What does the word extrapolate mean? What is the opposite of extrapolate?

9. What is the accepted value for absolute zero, in °C? _____

10. Scientists have devised a scale called the Kelvin scale (K) based on setting the accepted absolute zero value equal to 0 K, but using the same size unit as the Celsius scale.

So what would 0°C be on the Kelvin scale? _____ How about 100°C? _____ 22°C? _____ -196°C? _____

11. Which is a more appropriate temperature scale to use, Kelvin or Celsius?

(Hint: Consider what temperature is a measurement of.) *Explain your choice.*

12. If you had used a gas with bigger molecules (like carbon dioxide) why would this not have affected the value you got for absolute zero? (Hint: reread the 2nd opening paragraph)

13. Why were there rocks in the boiling water? (*see the procedure*)

14. Scientists can cool substances down to near absolute zero (even as low as 0.00001 K) but they have never actually reached absolute zero. Why do you suppose that is? (*see WS 5.2*)

